

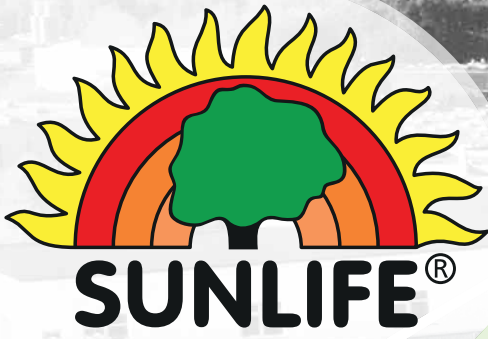

- Manufacturing
- Contract manufacturing
- Development

- Brand & Private Label

- Made in Germany





Karl-Heinz Almer



Christof Kara

CEO's SUNLIFE® GmbH

SUNLIFE is one of the leading manufacturers of dietary supplements in Europe.

We are a supplier for well-known trading partners in the food retail, pharmacy and pharmaceutical trade in over 90 countries.

SUNLIFE's success is based on our values, to which we have remained true to this day.

Orientation towards customer requirements and high-quality service form the basis of our success.

In addition, we create new, attractive and innovative ideas with added value for consumers, unique and attractive market positions, a solid foundation in the People-Planet-Profit philosophy and an effort to combine Technology - Ecology - Biology.

Reliability and trust, the courage to innovate and, above all, customer orientation are what make us stand out and make SUNLIFE the successful company it is today.



SUNLIFE® GmbH is a producer as well as a supplier to renowned international trading partners in the food retail and pharmacy sectors in over 70 countries.

SUNLIFE® GmbH is one of Europe's leading manufacturers of tablets, capsules and effervescent tablets for vitamins and minerals.

SUNLIFE® produces and markets a wide range of: food supplements, vitamin products, minerals, OTC pharmaceuticals, sports foods, wellness and dietary products, cosmetic and care products as well as medical products.

SUNLIFE® products offer premium quality, are manufactured according to GMP/HACCP guidelines and have ISO 13485 certification.

SUNLIFE® products are a low-price, high-quality alternative to expensive brands and are in ever-increasing demand.

SUNLIFE® products contain a carefully balanced combination of active substances geared to the daily requirements recommended by the German Association for Nutrition (DGE).

SUNLIFE® has a comprehensive, innovative range of products fulfilling the requirements and wishes of a variety of target groups.

SUNLIFE® is constantly developing new products in line with consumer demands in its own research and development department.

SUNLIFE® exploits its considerable experience to provide flexible product solutions, satisfying special, individual requests from its customers for private label or brand name products.

SUNLIFE® offers its business partners reliability, performance and a service orientated way of thinking and acting as important prerequisites for success.

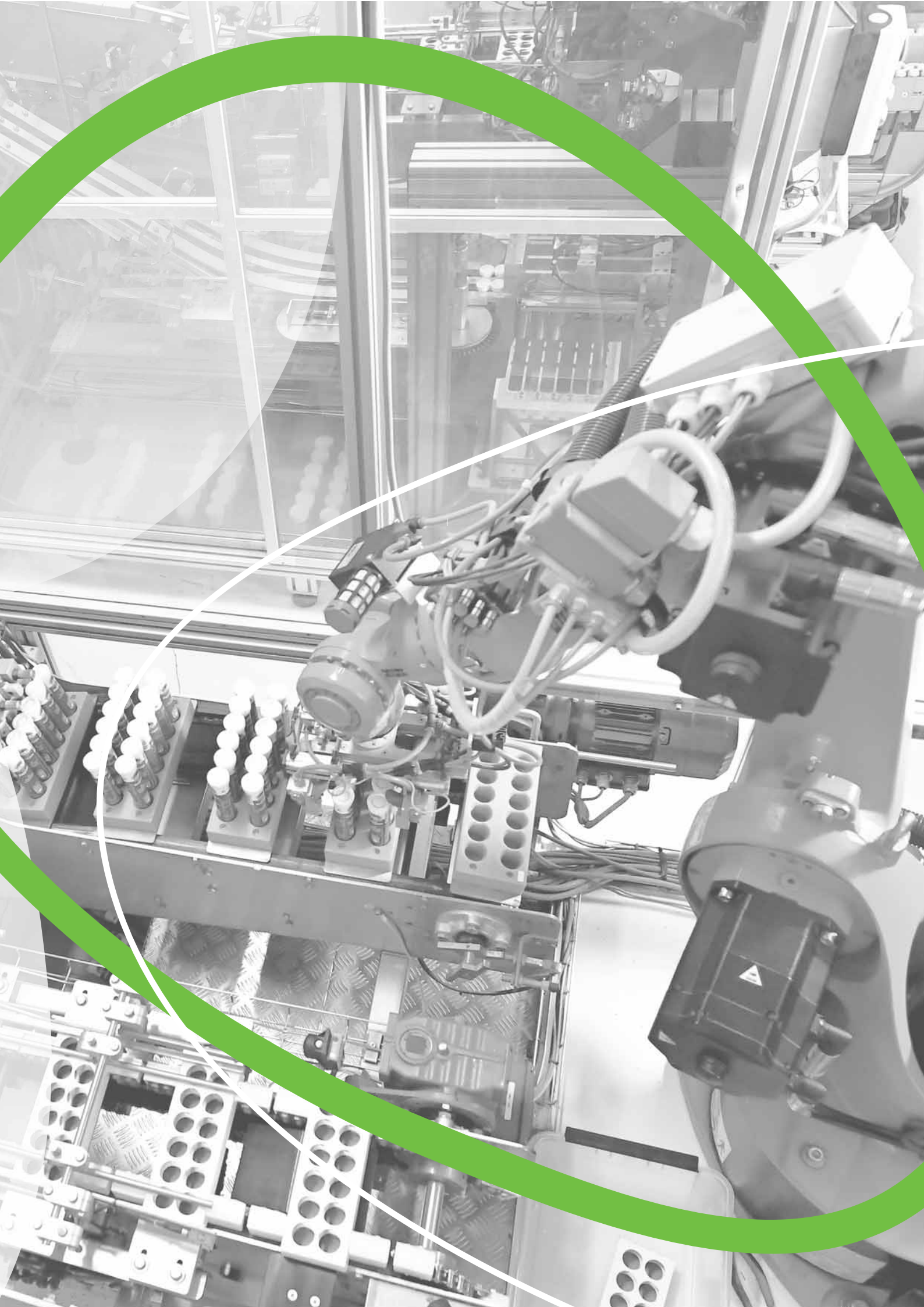



Internal quality management **Product quality assurance** **Regulatory affairs**

Quality is important to us. The market and our clients set the benchmark for quality. Our many years of experience in the industry let us provide the customer with a product that will be successfully approved for a highly regulated market. We guarantee a safe product for end consumers that complies with the highest quality and testing guidelines. Our quality system can be split up into three areas that accompany all ongoing processes and guarantee that our benchmarks are upheld.

Internal quality management

Internal SUNLIFE quality management is responsible for the maintenance, monitoring and constant updating of our company's own norms. SUNLIFE is a pharmaceutical entrepreneur and distributor of medical devices certified in accordance with DIN EN ISO 13485:2016. In order to maintain this certification, our quality management system is regularly checked by responsible external monitoring authorities.



Product quality assurance

Ongoing quality checks of our products ensure that these always comply with the latest guidelines for quality and safety. This involves ongoing in-process controls in production, monitoring of production documents after each batch is produced and, finally, a process of approvals to bring products onto the market. Additional quality assurance tasks include creating/requesting all required documents, such as specifications and certificates as well as laboratory tests and checking for regulatory market conformity.



Regulatory affairs

As a national and international distributor of food supplements, medical devices and pharmaceuticals, we are familiar with the complexity of the regulatory requirements when it comes to bringing new products onto the market as well as ensuring the ongoing marketability of existing products. The regulatory affairs department at SUNLIFE takes care of all legal requirements in terms of product safety, maintenance and the preservation of certificates and approvals to ensure products' conformity with all applicable guidelines and laws. This also includes clarifying borderline issues and checking packaging layouts for error-free and compliant labelling.

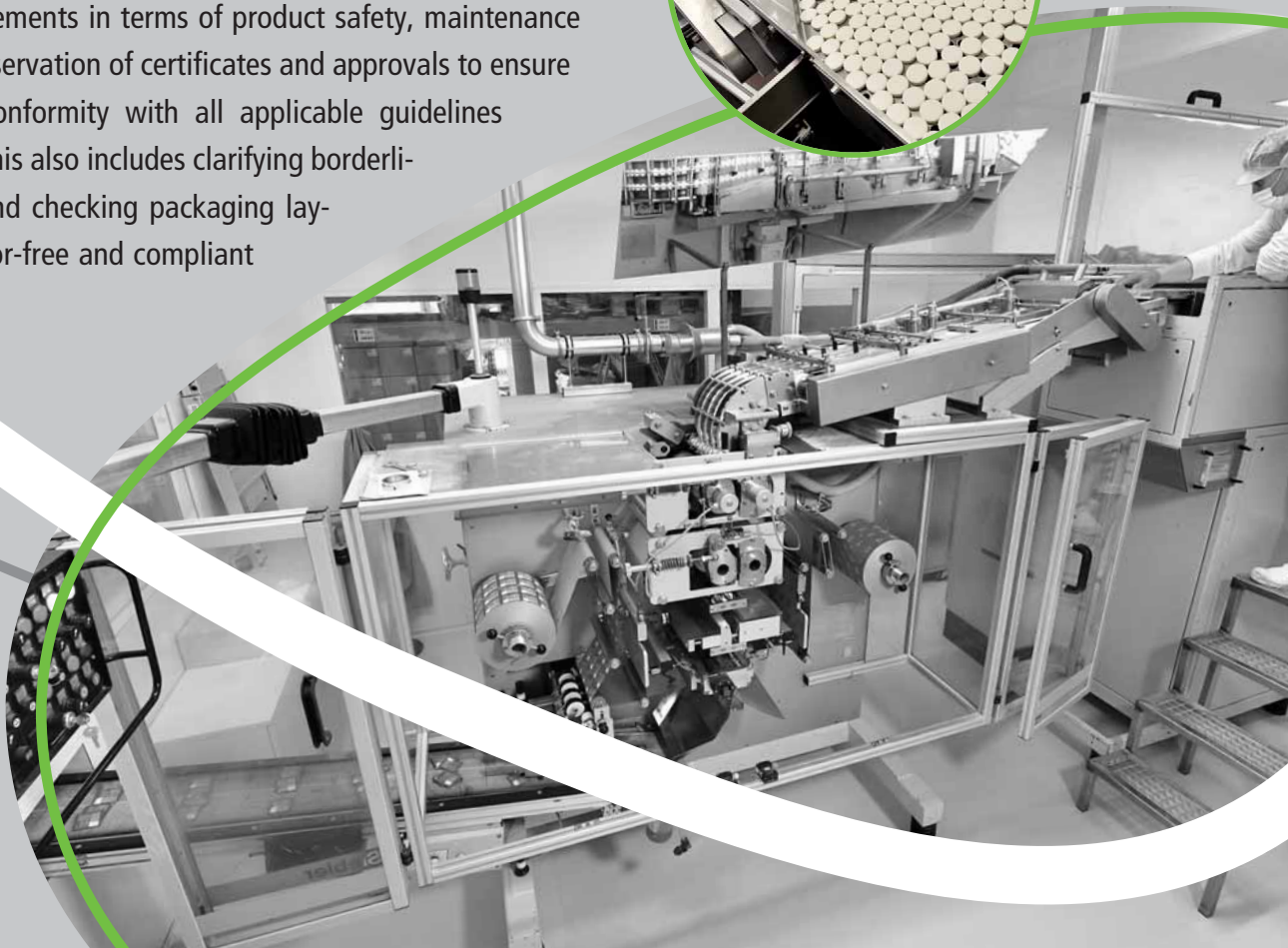



Your efficient full service partner

From the initial idea to final implementation we see ourselves as a real full service provider that guides its clients on their journey through to final product implementation and beyond. For each area, we make the right specialist available to our clients. Beginning with detailed advice, we take care of the successful realisation of production, design and the circulation of new products, and remain at your side with sage advice even after the product launch.

Setting benchmarks

Paving the way instead of following the herd. The health sector is in constant change. Here at SUNLIFE, we live and breathe innovation and constantly develop new products for our fast-selling own brands as well



as our private label customers. Our innovations create progress and portfolio competence, allowing us to generate new sales potential for our customers. Our internal science and regulatory affairs departments are always at your side during new developments to ensure that the product complies with the latest scientific knowledge and fulfils all regulatory requirements for a successful market introduction.

The customer takes centre stage

Our actions revolve around two things: our customers' satisfaction and success.



Are you looking not just for the right product, but also a strong service provider to serve as your partner? SUNLIFE has been a well-established contract manufacturer for retailers and brands at a national and international level for many years, and boasts a broad spectrum of products and services. We are happy to use our expertise in production, product safety and marketing for our clients, and always orientate ourselves based on the goals and requirements given to us. We treat our clients as equals and will be at your side for the duration of the whole project and beyond with advice and solutions.

Here at SUNLIFE, we observe and evaluate emerging trends in the health industry, constantly inform ourselves about new and improved raw ingredients and develop ideas for innovative, new products including well-considered and attractive packaging solutions. We don't just come up with product concepts, rather complete range concepts.

We constantly develop and improve our products to take advantage of growth sources on the market. There's hardly any other sector that changes quite as much as the health industry. New scientific knowledge sets new standards for the optimal efficacy of products almost every day. In light of all these changes, it's important to keep sight of the bigger picture.



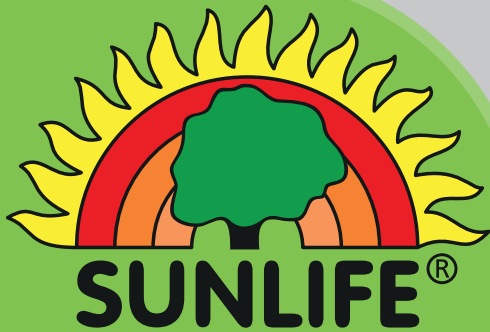

Full Line Provider

We are a real multi-talent. We offer a wide variety of dosage forms in diverse packaging options and indications, thus covering a broad product portfolio.

Full service and partner for your brand

As a true full-service provider, we support you in all key aspects of your product or brand launch. Our services in detail: Category management, Legal assessment and advice on the product group, Competitive monitoring and market research, Creation and implementation of placement, brand, and design concepts, Product range analysis, Consumer service and communication.



Tablets



Effervescent tablets



Bi-Phase Liquids



Pregnancy test



Lozenges



Fizzing Lozenges in special forms (bear, elephant)



Ointments



Pregnancy Test strip



Oblong tablets



Sprays



Pregnancy Early test



Hard gel capsules



Powder



Tea's



Ovulation test



Depot capsules

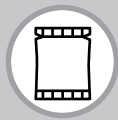

Sachet poche



Nasal douche



Packaging: Boxes



Soft gel capsules



Stick poche



Thermo-meter



Product displays



Pastilles



Liquids



Tablet dispenser



Counter displays

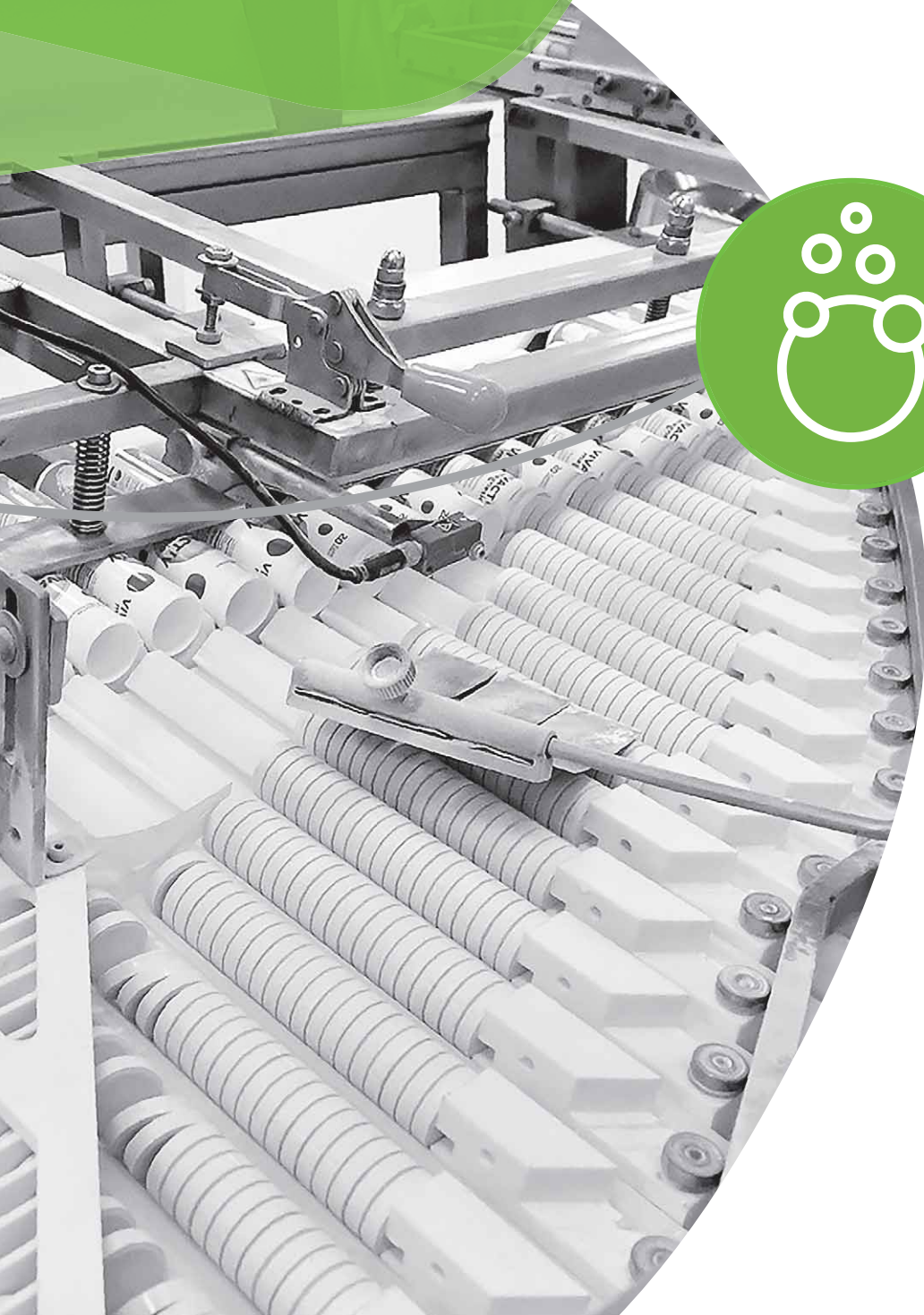

Effervescent tablets (Tubes) - Overview of dimensions



Tube
70 mm x 29 mm
 Letterset
 (4,0 - 6,5 g
 Ø 25 mm tablets)

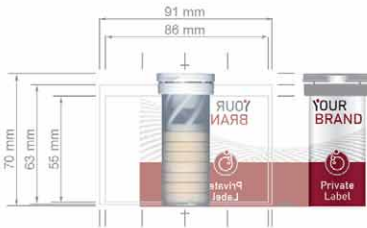

Tube
85 mm x 31,5 mm
 IML
 (4,0 - 6,5 g
 Ø 25 mm tablets)

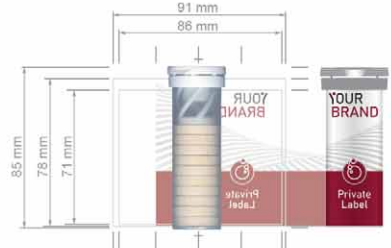

Tube
120 mm x 31,5 mm
 IML
 (4,0 - 6,5 g
 Ø 25 mm tablets)

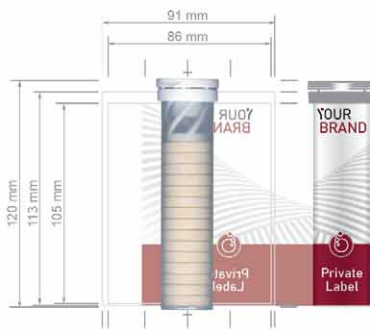

Tube
144 mm x 31,5 mm
 IML
 (4,0 - 6,5 g
 Ø 25 mm tablets)

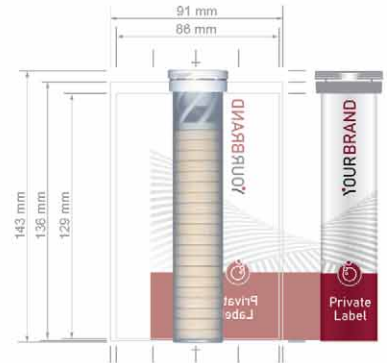

Tube
175 mm x 29 mm
 Letterset
 (4,0 - 6,5 g
 Ø 25 mm tablets)

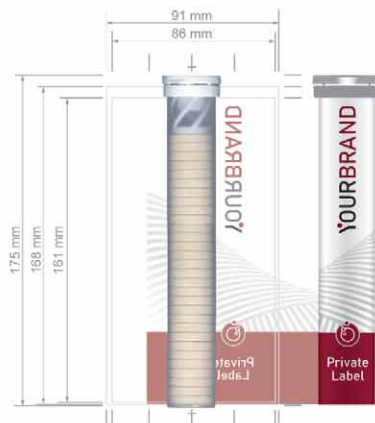

Tube
126 mm x 38 mm
 Letterset
 (7,0 - 11,0 g
 Ø 33 mm tablets)

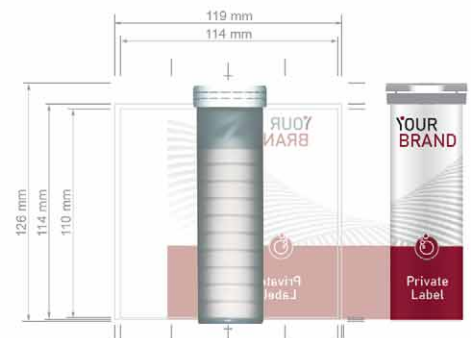

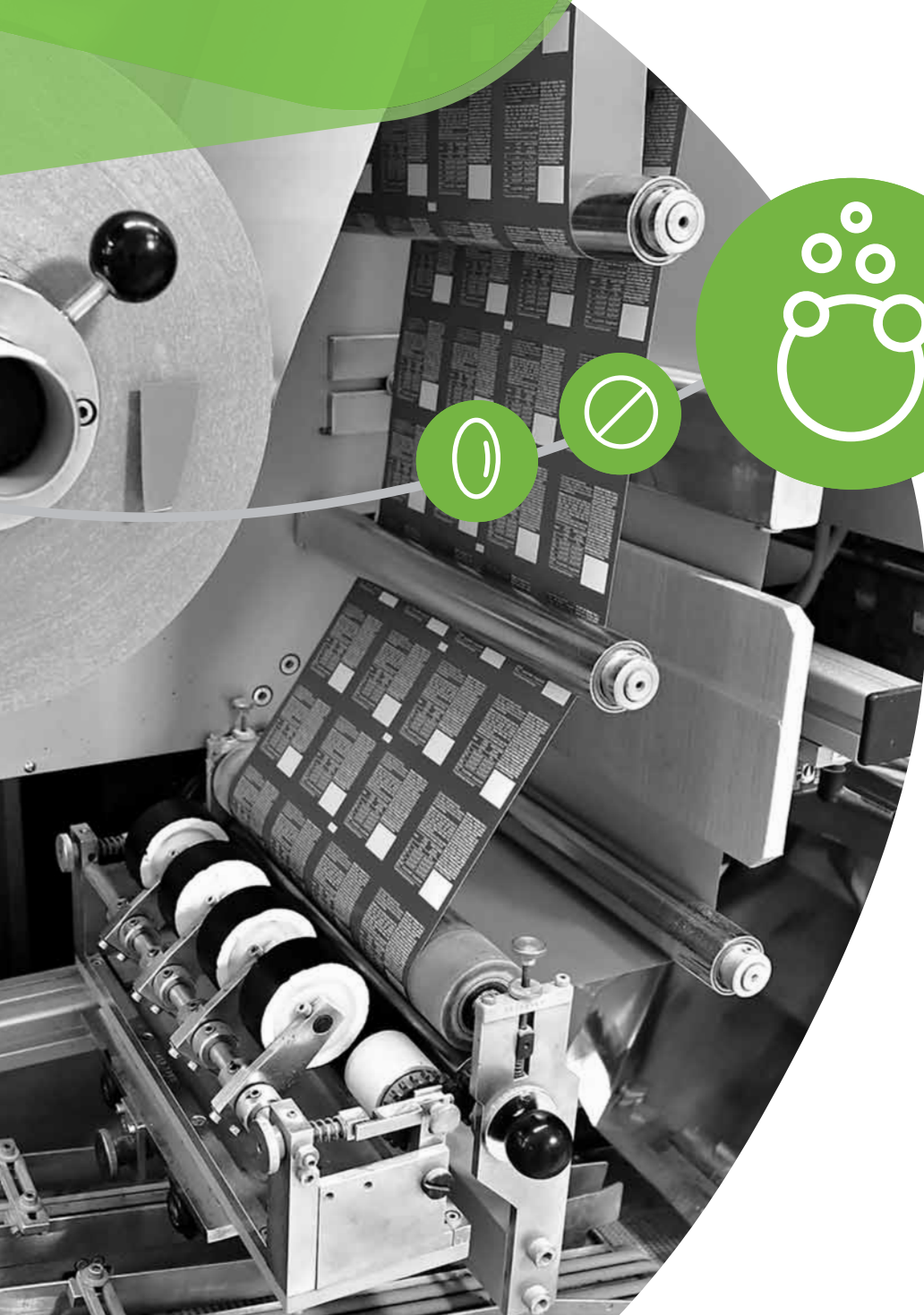

Sachets - Overview of dimensions



60 x 60 mm



80 x 80 mm

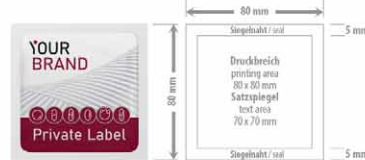

80 x 160 mm



60 x 120 mm

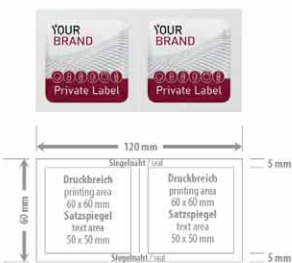

80 x 70 mm



80 x 140 mm

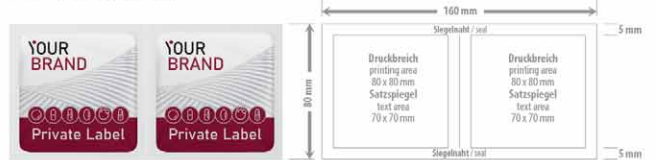

120 x 120 mm

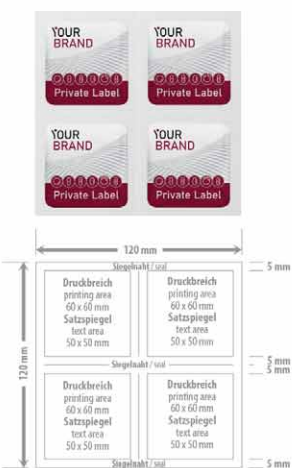

100 x 80 mm



100 x 160 mm



100 x 80 mm



100 x 160 mm





Stickpacks - Overview of dimensions



90er bis/until 2 g



100er bis/until 3 g



105er bis/until 4 g

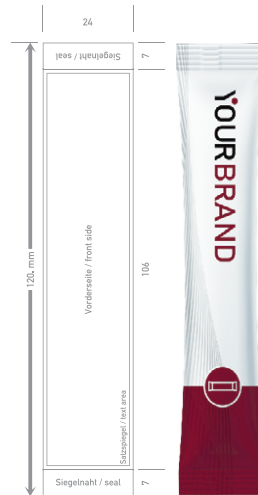

120er bis/until 5 g



135er bis/until 7 g



Jars/Bottles - Overview of dimensions



Product: 50er
 Closure system:
 Snap-on
 Lid with snap closure,
 guarantee closure
 Diameter: 45 x 50 mm
 Round
 Capacity: 50 ml



Product: 75er
 Closure system:
 Snap-on
 Lid with snap closure,
 guarantee closure
 Diameter: 45 x 70 mm
 Round
 Capacity: 75 ml



Product: 100er
 Closure system:
 Snap-on
 Lid with snap closure,
 guarantee closure
 Diameter: 45 x 85 mm
 Round
 Capacity: 100 ml



Product: 150er
 Closure system:
 Snap-on
 Lid with snap closure,
 guarantee closure
 Diameter: 60 x 85 mm
 Round
 Capacity: 150 ml



PET Packer: 75er
 Closure combination:
 Screw system,
 foam insert
 Diameter: 48 x 88 mm
 Round
 Capacity: 75 ml



PET Packer: 100er
 Closure combination:
 Screw system,
 foam insert
 Diameter: 48 x 105 mm
 Round
 Capacity: 100 ml



Blister - Overview of dimensions

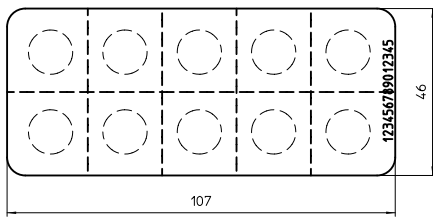

107 x 46 mm - 10er (61010189a)

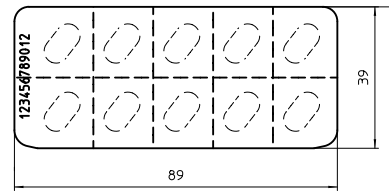

89 x 39 mm - 10er (61012165)

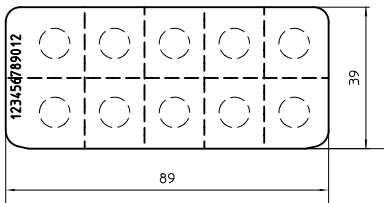

89 x 39 mm - 10er (61012164)

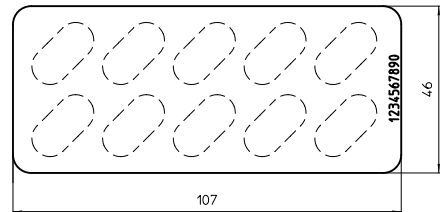

107 x 46 mm - 10er (61010262a)

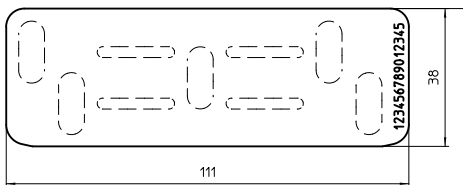

111 x 38 mm - 5er (61014614a)

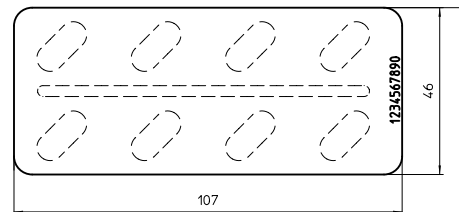

107 x 46 mm - 8er (61010700)

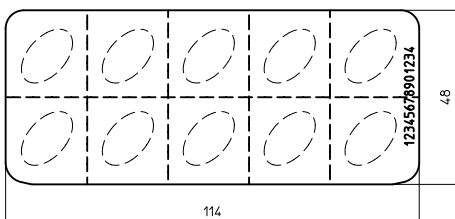

114 x 48 mm - 10er (61011698b)

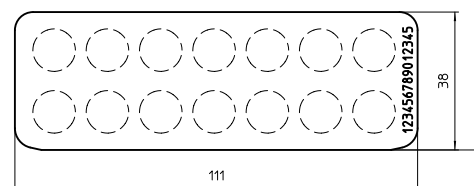

111 x 38 mm - 14er (61011862)

Blister - Overview of dimensions

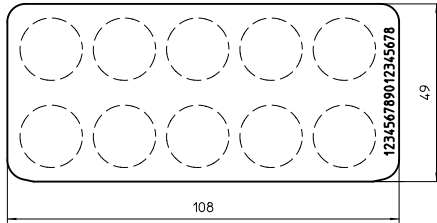

108 x 49 mm - 10er (61013498)

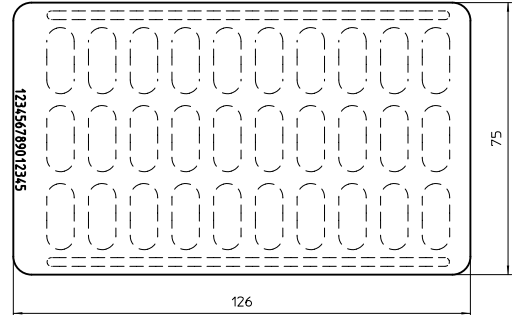

126 x 75 mm - 30er (61010264a)

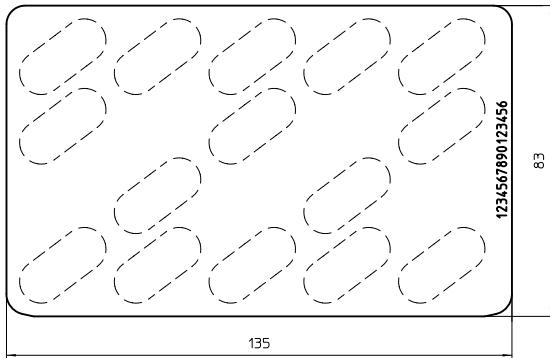

135 x 83 mm - 15er (61015379a)

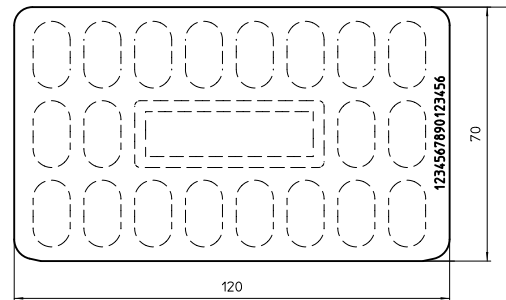

120 x 70 mm - 20er (61013451)

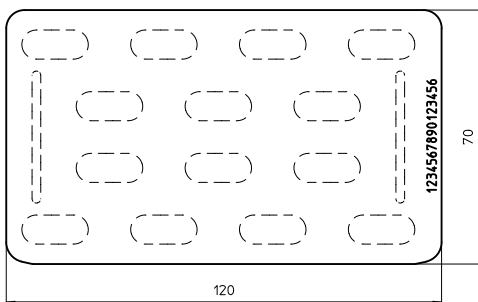

120 x 70 mm - 14er (61014583a)

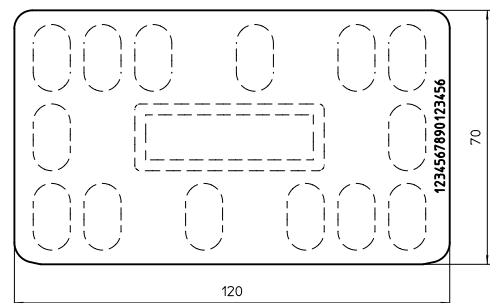

120 x 70 mm - 14er (61013616)

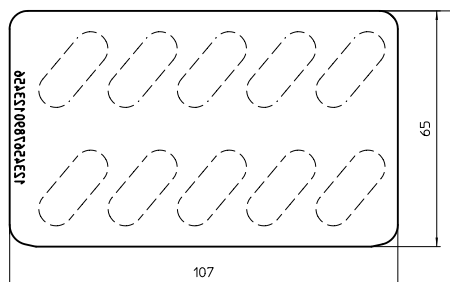

107 x 65 mm - 10er (61014660b)

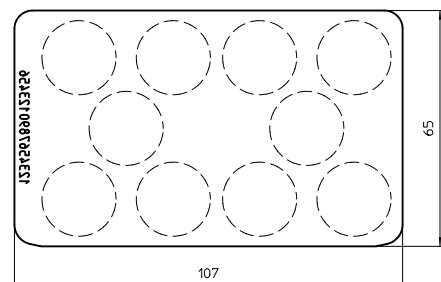

107 x 65 mm - 10er (61014661b)

Blister - Overview of dimensions

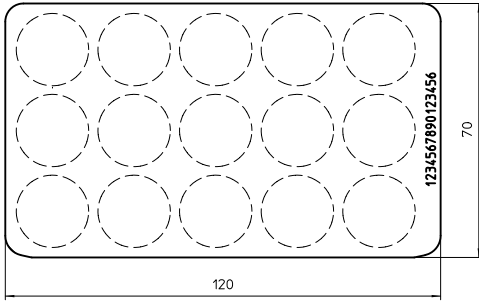

120 x 70 mm - 15er (61015086a)

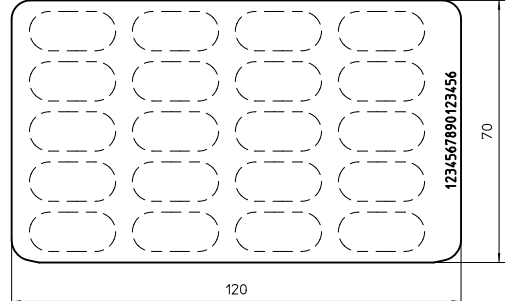

120 x 70 mm - 20er (61015374a)

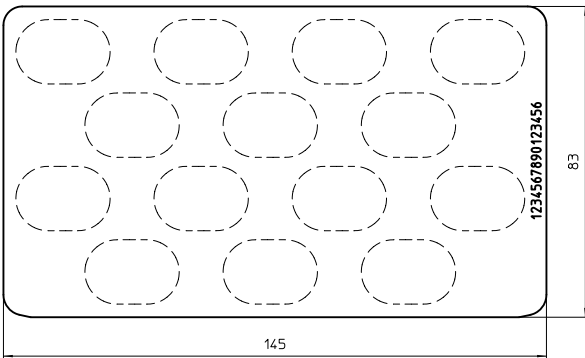

145 x 83 mm - 14er (61015255a)

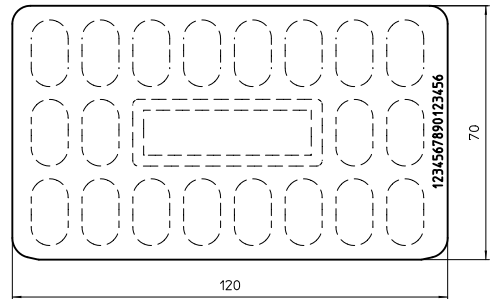

120 x 70 mm - 20er (61015411a)

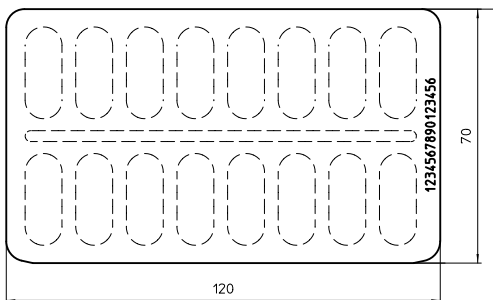

120 x 70 mm - 16er (61013242)

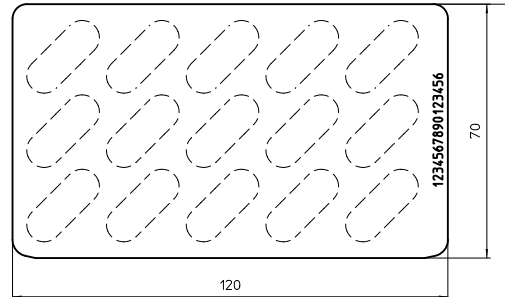

120 x 70 mm - 15er (61015433a)

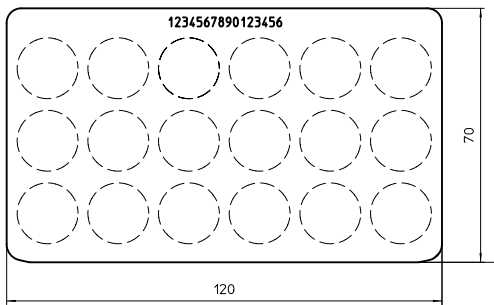

120 x 70 mm - 18er (61015436b)

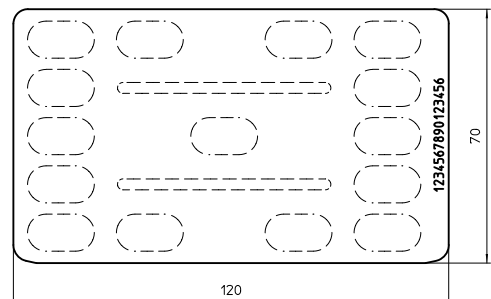

120 x 70 mm - 15er (61015438a)

Blister - Overview of dimensions

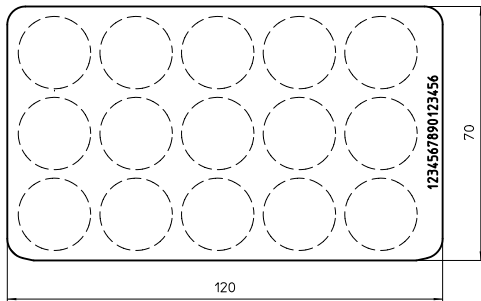

120 x 70 mm - 15er (61015086a)

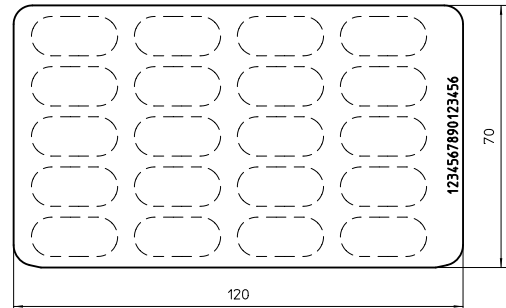

120 x 70 mm - 20er (61015374a)

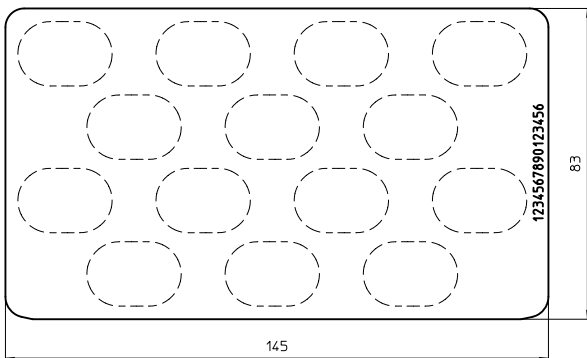

145 x 83 mm - 14er (61015255a)

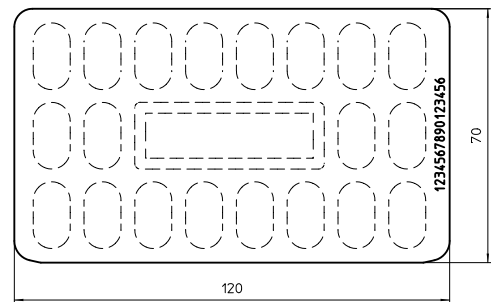

120 x 70 mm - 20er (61015411a)

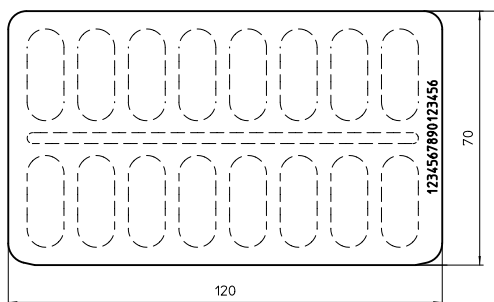

120 x 70 mm - 16er (61013242)

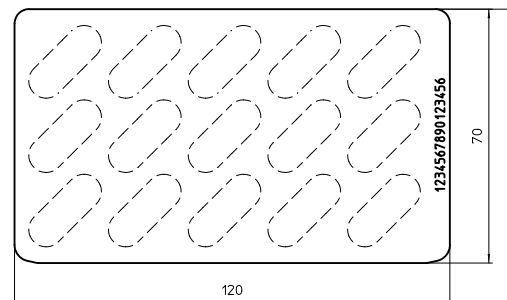

120 x 70 mm - 15er (61015433a)

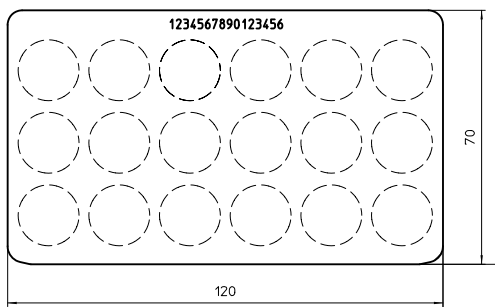

120 x 70 mm - 18er (61015436b)

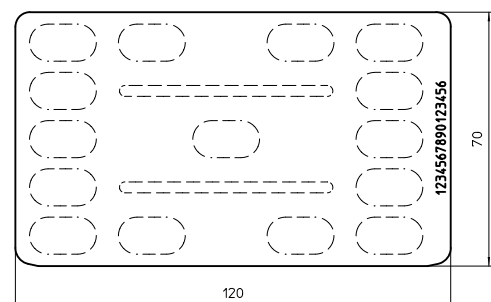

120 x 70 mm - 15er (61015438a)

Blister - Overview of dimensions



Other sizes,
please
contact us!



Various - Overview dosage forms

YOUR BRAND at its best



Flaschen (Tinktur/Säfte/Öle/Bäder)
Glas bottles (Tincture/Juices/Oils/Liquids/Baths)



Tuben (Salben/Cremes)
Tubes (Ointments/Creams)

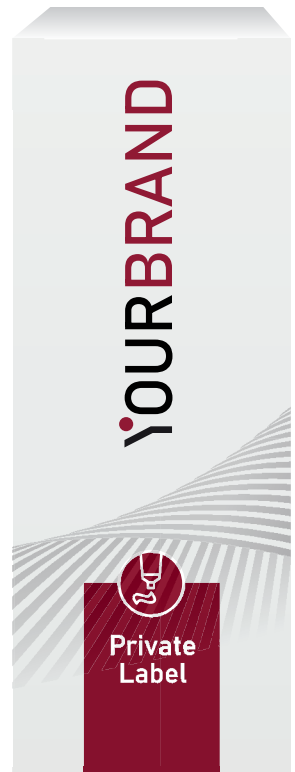
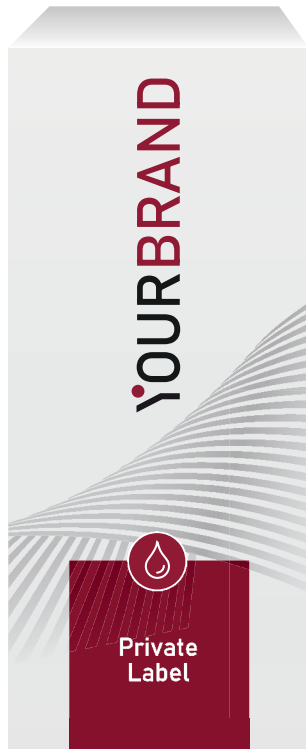

Various - Overview dosage forms



Tablettenspender (Klickspender)
Dispenser (Klick dispenser)



Tablettenspender (Klickspender - Süßstoff)
Dispenser (Klick dispenser - sweetener)



Tabletten Box
Plastic box (Dispenser)



Sprays (Nasenspray)
Sprays (Free nose spray)



Various - Overview dosage forms



Dose (Pulver)
Plastic container (Powder)



Bi-Phase-Ampulle (Liquid Mix)
Bi-phase ampoule (Liquid Mix)



Medizinprodukte (in-vitro-diagnostika)
Medical devices (in vitro diagnostics)

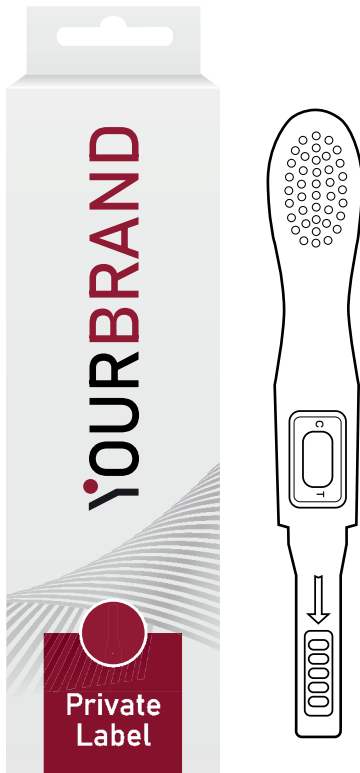

Medizinprodukte (Thermometer)
Medical devices (Thermometer)

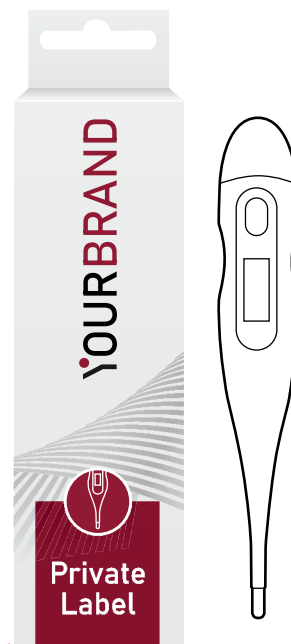



World Wide Shipping

Our efficiency is manifested at every stage of the comprehensive challenge posed by transport and logistics.

Our distribution warehouse is equipped for loading and transporting large consignments.

With a rigid organisation and the efficient employment of personnel and software, we can cope with projects of any volume.

You can benefit from our wealth of transport experience with regard to both execution and security.







■ **SUNLIFE®**
Produktions- und
Vertriebsgesellschaft mbH
Schierbusch 3
33161 Hövelhof - Germany

■ www.sunlife-online.de
info@sunlife-online.de

